

# Continental™

## 1100L

With over 1.2 million units bought, and in use by nearly nine out of ten UK local authorities, the Continental™ 1100L is the undisputed benchmark for waste and recycling containers.



# Continental™ 1100L

Stylish and easy to use, this 4 wheeled bin can be configured to your most exacting requirements, on even the most demanding waste collection rounds. From DIN points and Danish Handles, to Lid Locks and corporate livery, the Continental™ 1100L is the most adaptable commercial waste bin around.



No wonder it's the winner of a World Industrial Design Award.

Quality manufacture means Continental™ bins keep working, even under the toughest conditions. Like all Taylor metal waste and recycling bins, the Continental™ 1100L has a hard wearing galvanized steel body and base.

Internally welded seams stop water penetration, preventing the corrosion that plagues less well made metal waste containers. With full EN840 certification, they will give you exceptional lifetime value with limited down time, unlike plastic and other alternative steel commercial trade waste bins.

## Optional Spares and Accessories:

- Locking Post Bracket
- A Range of Body and Lid Colours
- Danish Handles
- DIN Points
- Embossing
- Recycling Lid
- New Forest Lock
- Tag Safe
- Drop Front
- Drop Back
- Foot Operated Lid
- Sound Deadening

## Applications

- Clinical waste
- WEEE bin
- Cage bin
- Duo bin
- General waste collection
- Dry mix recyclables

## Features

- Internally seam welded
- Hot dip galvanised
- EN840 compliant
- Facility for ID chip
- Robust steel hinge
- Patented top frame
- Patented comb bar

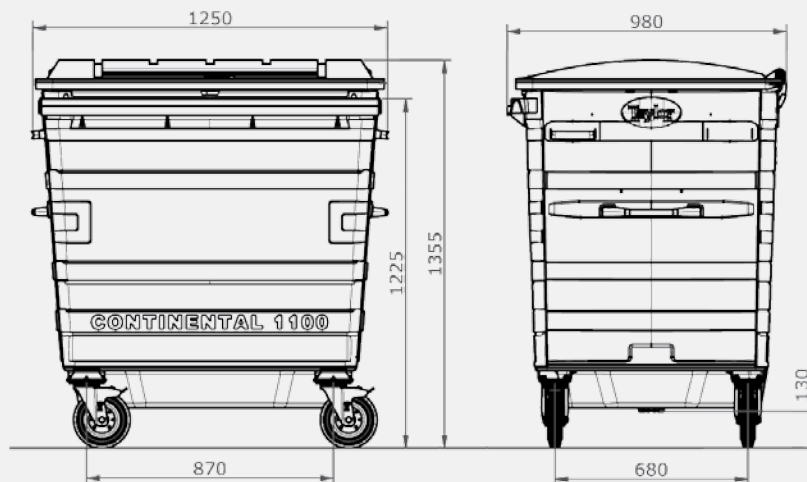

**Talk to us**  
+44 (0)1299 251 333

**Email us**  
sales@taylorbins.co.uk

**Visit us online**  
www.taylorbins.co.uk

