

Chamberlain™ 940 Litre Technical information



Product Image & Key Features

- Optional Double skinned UV resistant rotary-moulded lid. Available in black
- Facility for ID chip in frontal receiver to EN 14803
- Comb lifting bar (frontal receiver) to EN 840-2
- Rigid steel construction helps to contain a fire improving safety for residents
- Sump base for improved rigidity and stability
- Drain plug
- Recessed handles available reducing overall width (see technical drawing)
- Zinc galvanised steel
- Shape reduces over spill when in waste chutes
- Steel centred castors manufactured to Taylor's specification

Technical Drawing

Empty Weight
102.5KG + 5KG for lid

Safe Working Load
375KG

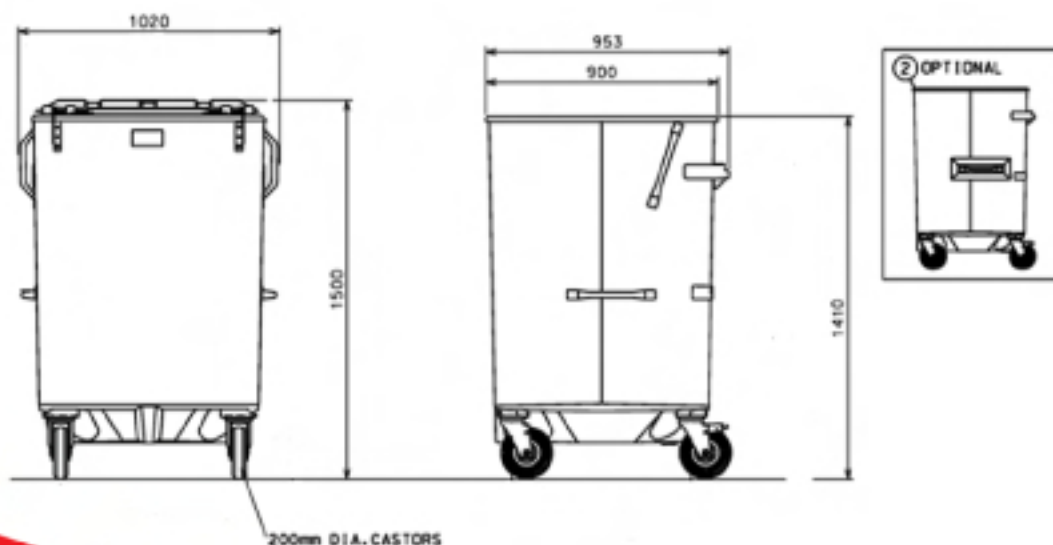

**the name
for innovation.**



INVESTOR IN PEOPLE

talk to us
01299 251 333

e-mail us
custserv@taylorbins.co.uk

online
www.taylorbins.co.uk

All dimensions are shown in mm and are for information purposes only.

Taylor, Chamberlain, Chamberlain, Taylor Street are trademarks. Taylor record, register and enforce their intellectual property rights. Taylor maintains a policy of continuous research and development, specifications are subject to alteration without notice.

Issued February 2011 (v2)